

Largo LAX 110 45 Specifications

- **1 x 90mm Waste and overflow with Basket Strainer Waste.**
Capable of adaptation to take Waste Disposal Unit
- **Jumbo Bowl**
- **Large diagonal dimensions**
- **Available as a Designer Pack**

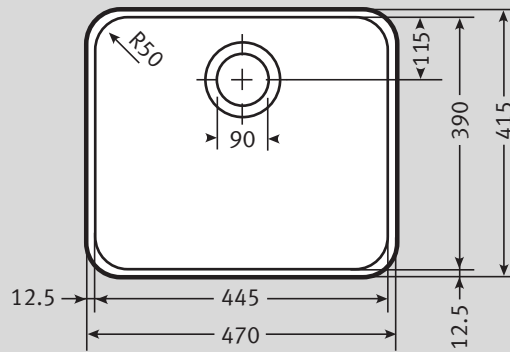

Material:	Stainless Steel
Application:	Undermounted
Bowl Size:	445 x 390 x 175
Drainer Format:	N/A
Cut-out Size:	Utilise template
Colour:	Silk Stainless Steel
Seal:	Apply sealant locally
Insulation:	Factory fitted Black Pads
Heat Resistance:	Up to 300°C
Earthing Point:	Supplied with sink

Cabinet Size:	
	*Ensure mounting system can be accommodated in cabinet

Fixing Clips:	G-Clips

Suggested Plumbing Kit:	Siphon 1

Waste:	1 x Lira 90mm Semi-Integrated Basket Strainer Waste with overflow	Overflow:	

Accessories:	None available
	<p>Drainer Basket Stainless Steel</p> <p>Rollamat 40</p>

Taps:	Any Franke tap can be utilised with this model*.
	*Ceramic disc taps in certain installations or where there is a low head of water (below 4 metres) may not provide adequate flow rates. You are advised to check with your supplier.

Guarantee: Franke sinks are guaranteed for 50 years against manufacturing defect. Franke taps are guaranteed against defective materials and workmanship for 1 year in relation to coatings and finishes, and 5 years in relation to moving parts. Franke will replace (and where appropriate repair) defective sinks. In relation to taps, Franke will where appropriate provide replacement parts for your taps or replace your taps. Any associated or ancillary costs to be incurred by you as a result of replacement of Franke sinks and taps under this guarantee shall in all cases be previously approved by Franke UK Limited.
This guarantee is in addition to and does not affect your statutory rights.